

MADAULA S.A.

www.madaula.com

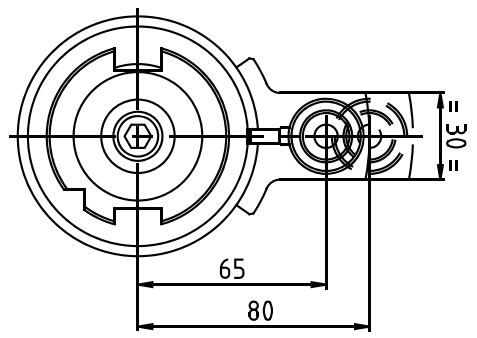

MV-9

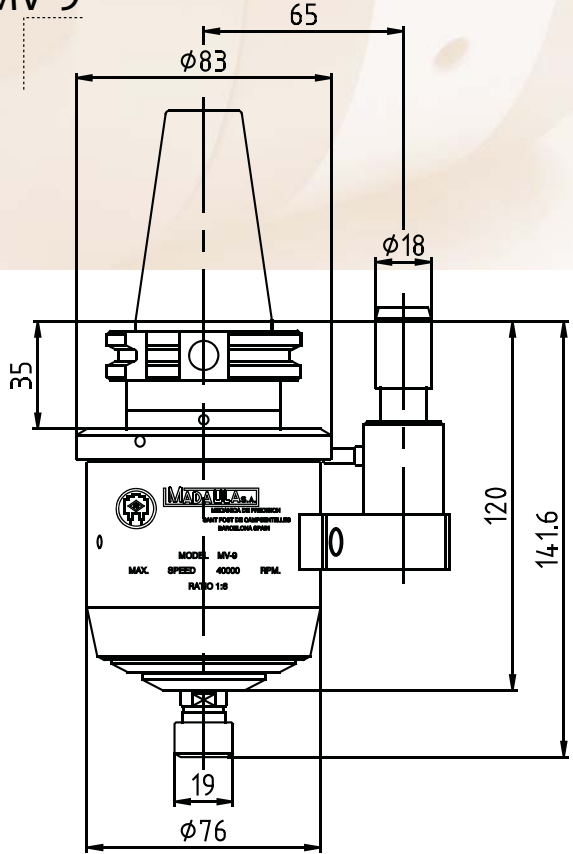

RPM: 40.000

 Ø Max.7

► Spindel speeder Model MV-9

- Smooth and quiet running
- Precise and rigid compact manufacture
- Very high output per tool
- No maintenance, greased for life
- Great rigidity and high precision
- Maximum concentricity
- Other clamping systems, on request, (ABS, HSK, WELDON...)
- Adaptable to any model of machine
- Available with any type of taper
- Increases tool and machine life
- Tailor made to meet customer specifications upon request
- No need of coolant

**NEW
 NOUVEAU
 NEU
 NUEVO**



MANUAL / AUTOMATIC INDEX ARM

▲| All types of indexations



STANDARD STOP BLOCK

▲| Stop-block suitable for all machines types, available on request

CERAMIC

Precision bearings with ceramic balls

40.000 RPM

FEATURES

	R.P.M.		L	Ø D	Ø d			SIZE	HSK SIZE
MV-9	40.000	1:6	106	76	0,5-7	ER-11	3	30/40	63

HIGHER ROTATIONAL SPEED

